

THIS DRAWING IS UNPUBLISHED. RELEASED FOR PUBLICATION
 © COPYRIGHT BY TYCO ELECTRONICS CORPORATION. ALL RIGHTS RESERVED.

LOC	DIST	REVISIONS			
P	LTR	DESCRIPTION	DATE	DWN	APVD
AF	50	L1	REVISED PER ECR-07-018043	08AUG07	HMR PD

1 CONTINUOUS STRIP ON REELS

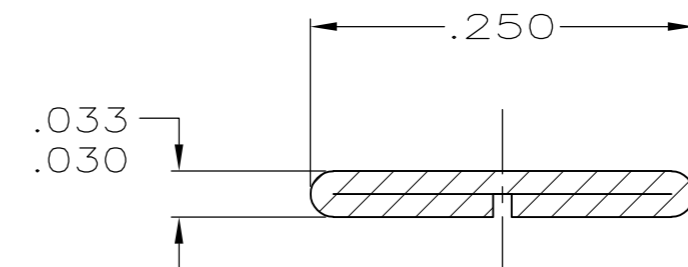
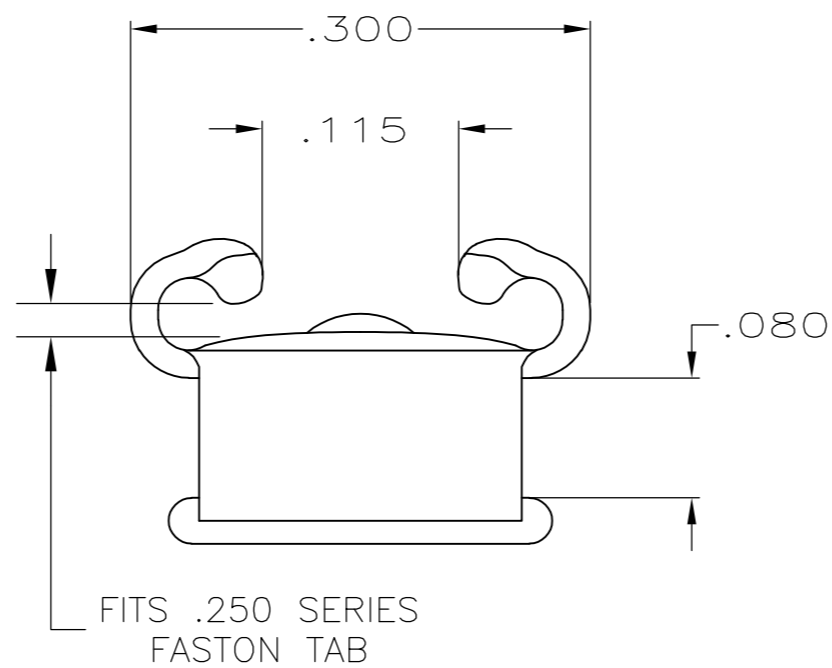
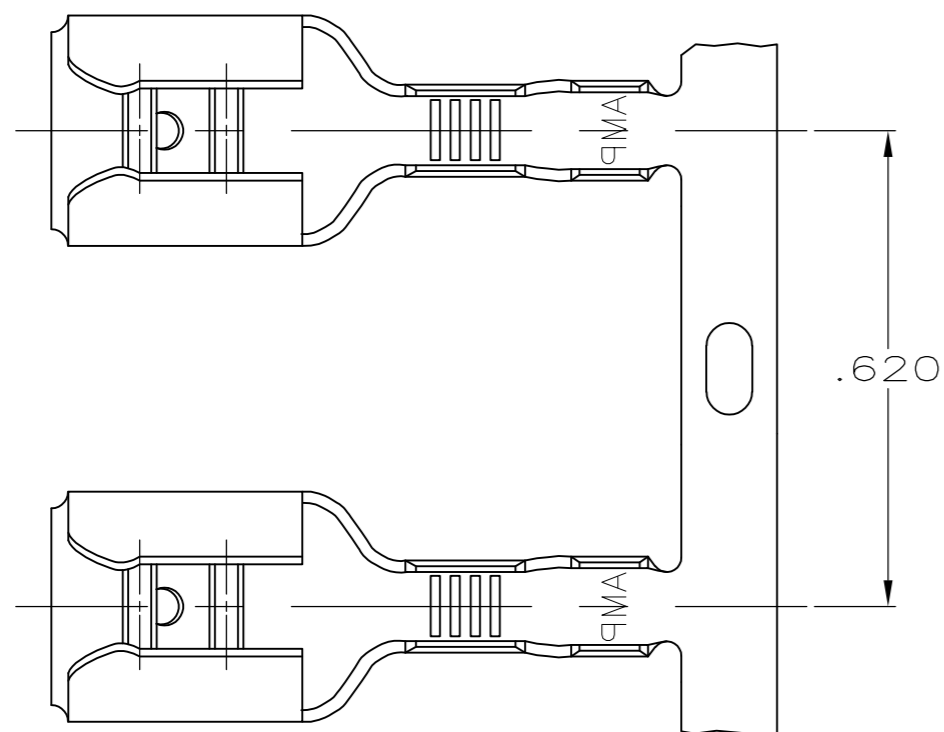

SECTION B-B
SCALE 8:1

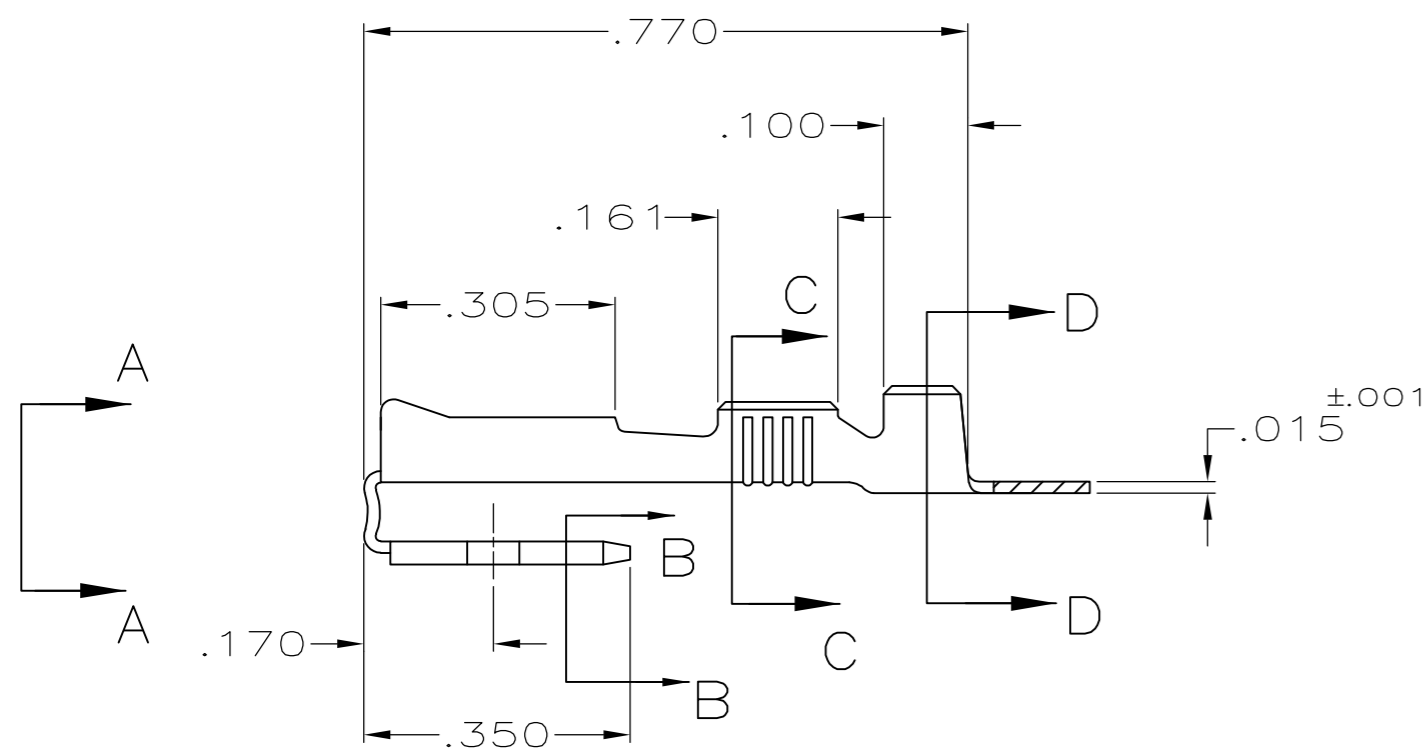

VIEW A-A
SCALE 8:1

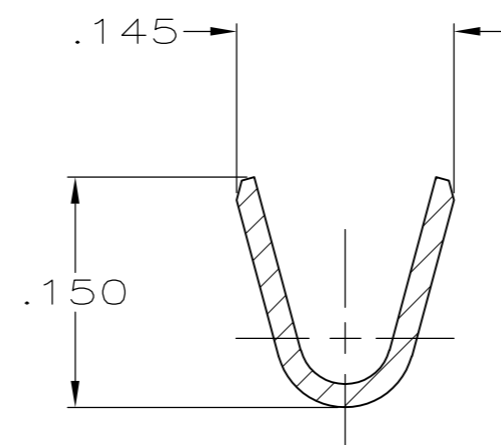

SECTION C-C
SCALE 8:1

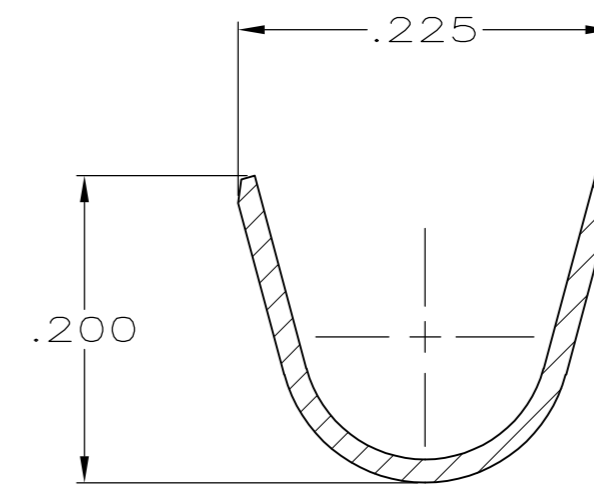

SECTION D-D
SCALE 8:1

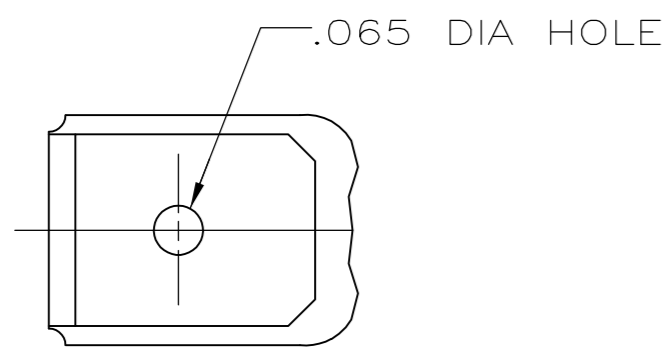

FINISH	MATERIAL	INSULATION RANGE	WIRE SIZE	MATING TAB THK ±.001	PART NUMBER	
OBSELETE	PRE-TIN	#4H BRASS	.120-.170	18-14	.032	42741-4
	TIN	#4H BRASS	.120-.170	18-14	.032	42741-2
	-	#4H BRASS	.120-.170	18-14	.032	42741-1

TYPE	WIDTH	STRIP LENGTH ±.015	TYPE	WIDTH	±.002 HEIGHT	WIRE
F	.180	.220	F	.110	.057	18
					.063	16
					.072	14
INSUL BARREL CRIMP			WIRE BARREL CRIMP			

THIS DRAWING IS A CONTROLLED DOCUMENT.

DWN	JR RUTH	7/12/89
CHK	MS FEHER	7/12/89
APVD	C MEYERS	7/12/89

Tyco Electronics Corporation
Harrisburg, PA 17105-3608

RECEPTACLE, FASTON,™
PIGGYBACK, .250 SERIES

SIZE	A2	CAGE CODE	00779	DRAWING NO	C=42741	RESTRICTED TO	-
WEIGHT	-	SCALE	4:1	SHEET	1 of 1	REV	L1

CUSTOMER DRAWING